

# Slimline Vogue® Bracket Dimensions

Key  
89mm Louvre Dimensions  
127mm Louvre Dimensions

ARCHITECTS | SPECIFIERS | CONTRACTORS

## Face Fix Brackets

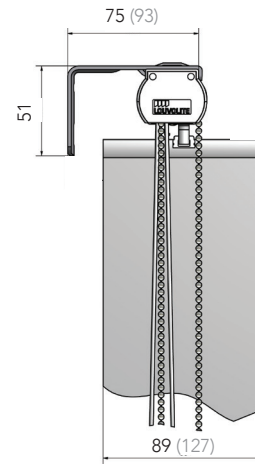

## Shallow Frame Face Fix Brackets

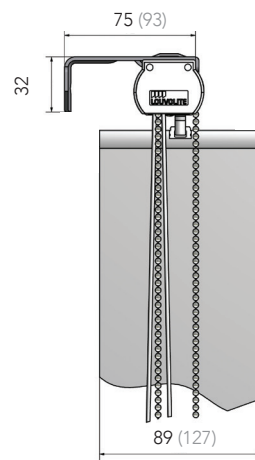

## Top Fix Brackets (screw)

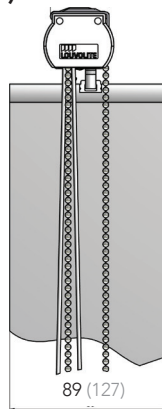

## Top Fix Brackets (spring)

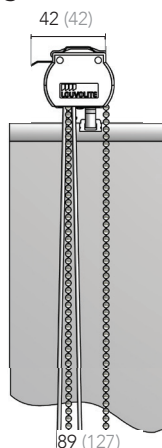

## Adjustable Face Fix Brackets

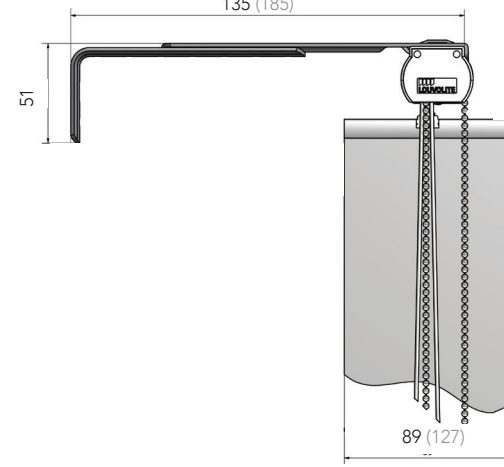

## Extension Top Fix Brackets

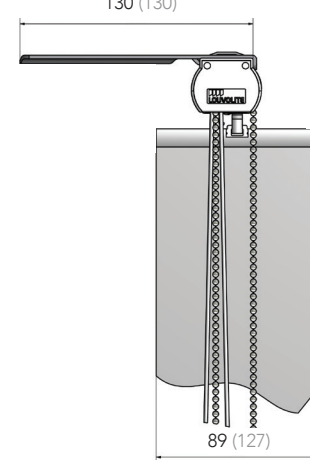

## Side Fix Brackets

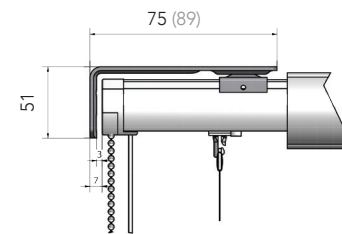

## Pelmet Brackets

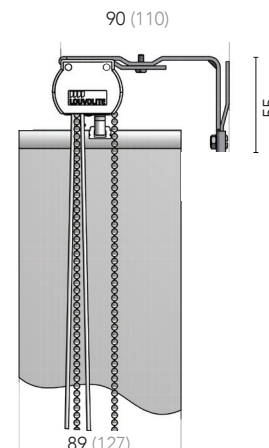

## Louvolve Slimline Vogue® Vertical Blind System

- Sleek curved headrail is unobtrusive, versatile, robust and designed to last many years.
- Includes quality materials such as stainless steel and aluminium with corrosion resistant finishes.
- 10 year life cycle tested
- Tracks are supplied up to 5000mm wide (16'.3") in White, Brown, Black, Aluminium or Champagne.
- Tracks come with fully enclosed end caps which house the operating cord and chain.
- UV Stabilised prime plastics used to guard against ultra violet degradation
- Direct drive tilt operation for positive control when opening and closing the blinds.
- Self-aligning carrier trucks have limit stops allowing the louvre to rotate to 185°
- Spacing controlled by stainless steel spacer links for extra durability.



**LOUVOLITE**

CIS/SIB 1976 reference by SIB Agency		
(76.7)	X	

# Hardware Specification

## Louvolve Slimline Vogue® Vertical Blind System

Vertical Blinds should be manufactured using the Louvolve Slimline Vogue® System with aluminium headrail 38.5mm x 28mm and include Louvolve carrier trucks with UV stabilised self-aligning hooks. The operating chain should be No 6 size metal to ensure reliable performance. The brackets used should be made from mild steel, zinc plated and powder coated and be suitable for top or face fixing.

The material used for the vertical louvre will be creased and punched so that a Louvolve UV stabilised hanger – also with a hole – can be stitched or welded into the top of the louvre.

## General applications

Vertical blinds incorporating the Slimline Vogue® headrail system provides a contemporary and extremely practical commercial

installation and are available from approved manufacturers worldwide. It is a robust and reliable system that has been specified for over 25 years.

The system is easily fitted and provides an extremely efficient method of light control. A large range of attractive flame retardant fabrics, and some featuring anti-glare SPC® and blackout coatings make these blinds the ideal choice for projects large or small. The fabrics are designed specifically for window blinds.

## Headrail

The Slimline Vogue® aluminium headrail extrusion is made from prime aluminium and is available in white and brown powder coated, silver anodised or polished black and champagne, which makes it corrosion resistant.

Brackets are zinc plated or powder coated and manufactured with a strengthening crease for increased strength and safety.

## Carrier Trucks

To ensure a positive and smooth operation within the headrail, all carriers are manufactured using prime quality plastic materials. This also provides durability and protection from embrittlement and UV rays. The gears in the carrier trucks that rotate the louvres are self-aligning with limit stops. This allows louvre rotation to 185°, which ensures an efficient closure without strain on the mechanism.

The spacing between the carrier trucks is controlled by high-grade stainless steel spacer links. The standard spacing is either 77mm for 89mm louvres or 115mm for

127mm louvres, although alternative spacing options are available.

UV stabilised louvre hangers are manufactured using Nylon No. 6 plastic.

## Operation

Operation is by either No 6 size chain or a tilt and draw wand control.

Slimline Vogue® tracks are smooth running and robust. The components are made in aluminium, prime plastic or stainless steel.

The design of the components minimises damage caused by operator misuse.



## Maintenance

All of the Slimline Vogue® components are manufactured using aluminium, plastic or stainless steel. They do not present any corrosion problems in normal environments.

The system has been designed for a smooth operation, together with a rigidity to prolong the window blind's working life. However any damage which does occur can normally be rectified on site.

## Louvres

Available as 89mm or 127mm width. All louvres are weighted and interlinked, front and back with ball and 'C' clip connectors.

Your Slimline Vogue® Distributor:

# Slimline Vogue® Components

## Headrail Section

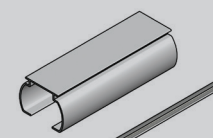

**Slimline Vogue® Headrail**  
**Product specification**  
 100% aluminium  
 Dimensions: 38.5mm (1 1/2") x 28mm (1 1/8")  
 Lengths: 5m (5.5 yard) maximum  
 Colour: white, brown, silver, gold or black

**Tilt Rod**  
**Product specification**  
 Aluminium

## End Cap Sets

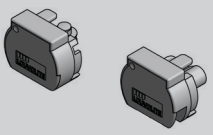

**Slimline Vogue® End Caps**  
**Product specification**  
 Nylon  
 Dimensions: 38.5mm (1 9/16") x 27.34mm (1 1/8")  
 Colour: white, brown, grey or black

## Carrier Trucks

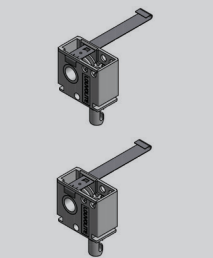

**Spade Hook**, self-aligning, 89mm or 127mm  
 For use with stainless steel spacer links

**Spade Hook**, fixed gear, 89mm or 127mm  
 For use with stainless steel spacer links

**Product specification**  
 Truck Body: nylon, link: stainless steel  
 Dimensions: 24mm x 32mm x 12mm  
 Colour: white, brown, grey or black

## Chain



Available in nickel plated brass, stainless steel or plastic. The pitch of the operating chain is designed to provide a smooth and silent operation. Available in a variety of colours, each chain system has a variety of connector units to allow for child safe operation where required.

**Product specification**  
 Acetal ball - colour: white, brown or black  
 Zinc plated - colour: silver, gold or black  
 Stainless steel  
 Easy break chain connector for child safety

## Stabalising Chain with C Clip



**Product specification**  
 Plastic  
 Sizes: 50mm, 63mm, 89mm, 127mm  
 Colour: white, black or beige

## Louvre Ballast Weights

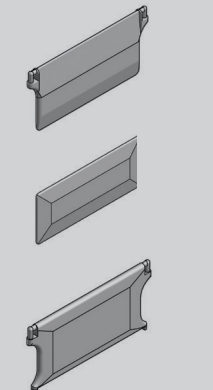

**Ballast Weights, Moulded, Compact**  
 89mm, 127mm  
**Product specification**  
 Colour: white, beige or black

**Ballast Weights, Moulded, Plain**  
 89mm, 127mm  
**Product specification**  
 Colour: white

**Ballast Weights, Moulded, Standard**  
 89mm, 127mm  
**Product specification**  
 Colour: white or beige

## Bracket Options

2 Brackets required for blinds up to 1 metre width, 1 further bracket required for every additional metre.

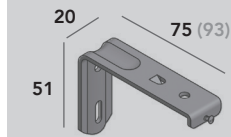

**Face fix brackets**, 89mm or 127mm  
**Product specification**  
 Mild steel, zinc plated and powder coated  
 Colour: white, brown or silver

Dimensions: 20mm (3/4") x 51mm (2") x 75mm (3") for 89mm (3 1/2") louvres  
 20mm (3/4") x 51mm (2") x 93mm (3 1/2") for 127mm (5") louvres

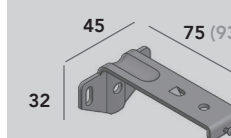

**Shallow frame face fix brackets**, 89mm or 127mm  
**Product specification**  
 Mild steel, zinc plated and powder coated  
 Colour: white, brown or silver

Dimensions: 45mm (1 1/2") x 32mm (1 1/4") x 75mm (3") for 89mm (3 1/2") louvres  
 45mm (1 1/2") x 32mm (1 1/4") x 93mm (3 1/2") for 127mm (5") louvres

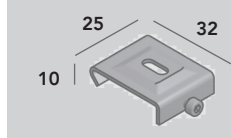

**Top fix brackets, screw**  
**Product specification**  
 Mild steel, zinc plated and powder coated  
 Colour: white, brown or silver

Dimensions: 25mm (1") x 10mm (3/8") x 32mm (1 1/4")

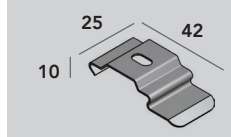

**Top fix brackets, spring**  
**Product specification**  
 Mild steel, zinc plated and powder coated  
 Colour: white, brown or silver

Dimensions: 25mm (1") x 10mm (3/8") x 42mm (1 3/8")

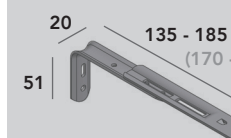

**Adjustable face fix brackets**, 135mm - 185mm or 170mm - 225mm  
**Product specification**  
 Mild steel, zinc plated and powder coated  
 Colour: white, brown or silver

Dimensions: short arm 20mm (3/4") x 51mm (2") x 135 - 185mm (5 1/4" x 7 1/4"), long arm 20mm (3/4") x 51mm (2") x 170 - 225mm (6 3/4" x 8 7/8")

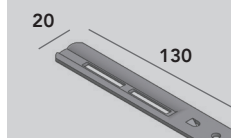

**Extension Top fix brackets**  
**Product specification**  
 Mild steel, zinc plated and powder coated  
 Colour: white, brown or silver

Dimensions: short arm 20mm (3/4") x 130mm (5 1/8") long arm 20mm (3/4") x 165mm (6 1/2")

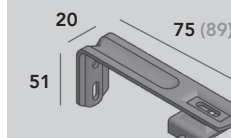

**Side fix brackets**, 89mm or 127mm  
**Product specification**  
 Mild steel, zinc plated and powder coated  
 Colour: white, brown or silver

Dimensions: 20mm (3/4") x 51mm (2") x 75mm (3") for 89mm (3 1/2") louvres.  
 20mm (3/4") x 51mm (2") x 89mm (3 1/2") for 127mm (5") louvres

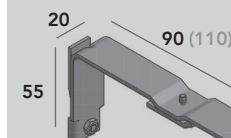

**Pelmet brackets**, 89mm or 127mm  
**Product specification**  
 Colour: silver

Dimensions: 55mm (2 1/8") x 20mm (3/4") x 90mm (3 1/2") for 89mm (3 1/2") louvres.  
 55mm (2 1/8") x 20mm (3/4") x 110mm (4 2/8") for 127mm (5") louvres

## Slimline Vogue® Monocommand®

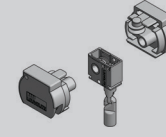

Alternative wand control - Child Safety Product  
**Product specification**  
 Colour: white, grey, brown or black

## Slimline Vogue® Monocommand® wand

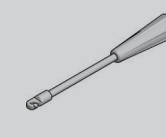

Available in lengths: 800mm, 1200mm or 2000mm

**Product specification**  
 Colour: white or black

## Cord Weights

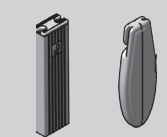

Available in Standard 80g, Teardrop 76g

**Product specification**  
 Colour: white or light grey

## Cord Tidy

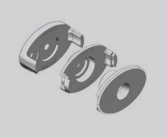

Double Cord & Chain Tidy

**Product specification**  
 Colour: white, brown or black

## Louvre Inserts

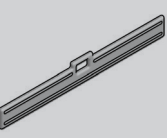

**Single Slotted Hole, Plastic**  
 50mm, 63mm, 89mm, 127mm: White  
 89mm, 127mm: Black

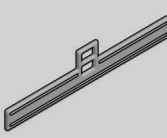

**Double Slotted Hole, Plastic**  
 89mm, 127mm

**Product specification**  
 Colour: white

## Shaped Blind Options

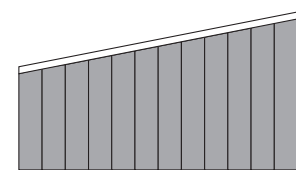

Angled Top

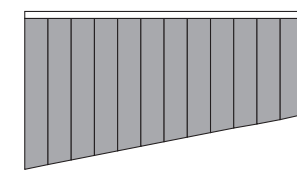

Angled Bottom

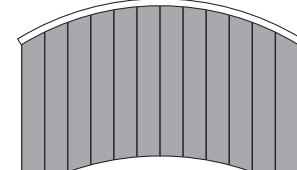

Curved Bottom

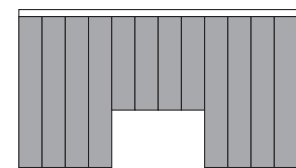

Shaped

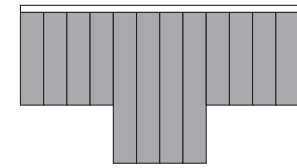

Stepped Bottom Edge

## Bunching Options and Stacking Distances

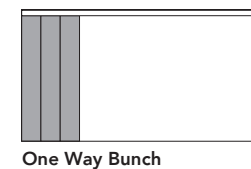

One Way Bunch

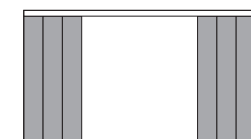

Split Bunch

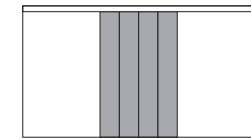

Centre Bunch

	89mm (3 1/2") Louvres	127mm (5") Louvres
Bunching		
One way	225mm (8 3/4") for 1st metre (3' 3") width of blind for each additional metre	190mm (7 1/2") for 1st metre (3' 3") width of blind. 115mm (4 1/2") for each additional metre
Split	225mm (8 3/4") for 1st metre (3' 3") width of blind. 175mm (7") for each additional metre	135mm (5 1/2") for 1st metre (3' 3") width of blind. 55mm (2 1/4") for each additional metre
Centre	165mm (6 1/2") for 1st metre (3' 3") width of blind. 165mm (6 1/2") for each additional metre	115mm (4 1/2") for 1st metre (3' 3") width of blind. 115mm (4 1/2") for each additional metre

## Slimline Vogue® Vertical Blind System

Exploded diagram:

### With Cord & Chain Operation

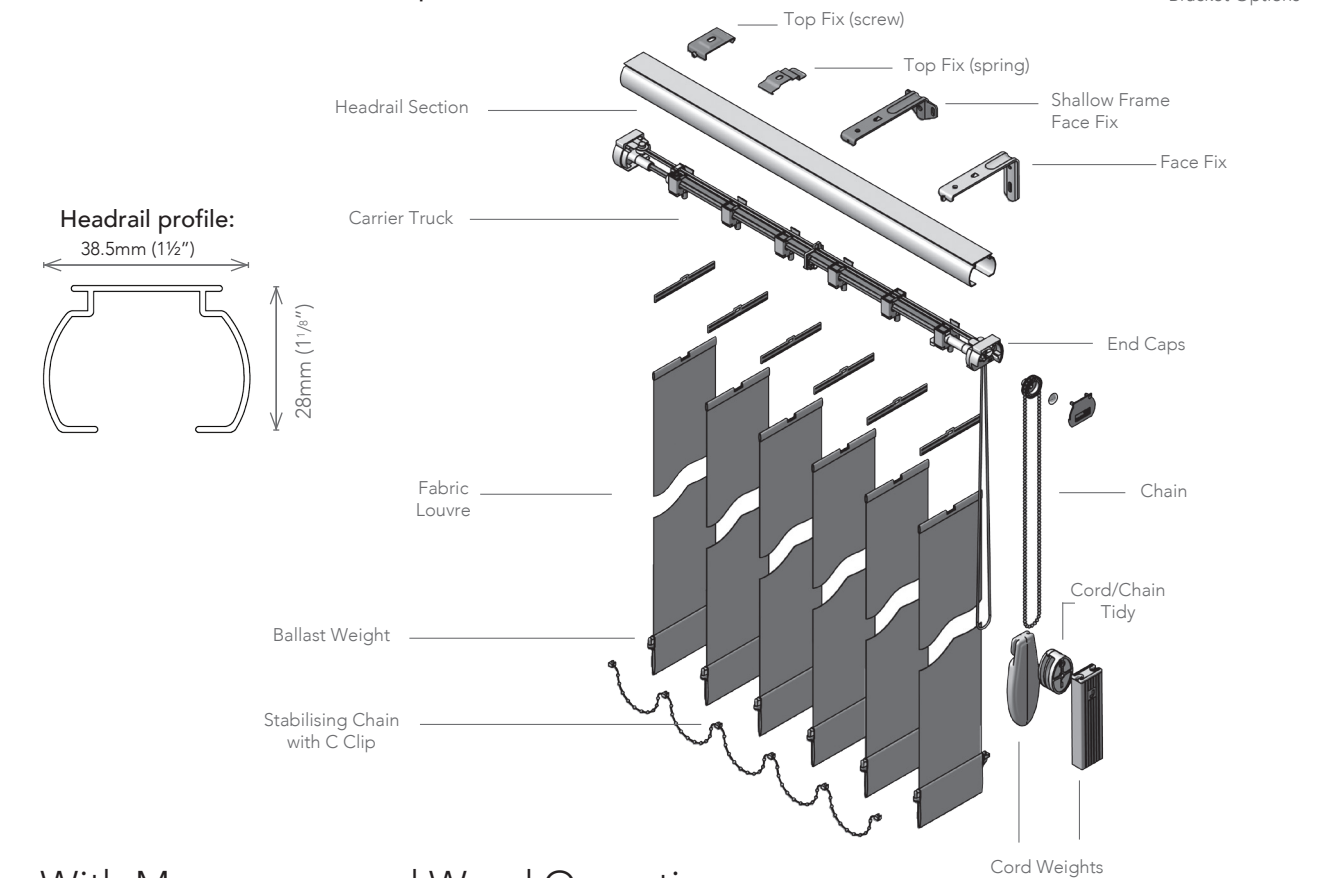

### With Monocommand Wand Operation

