

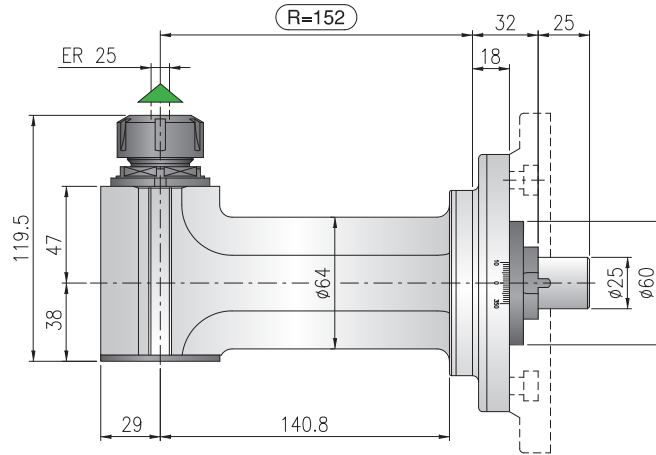

## T90-2,5L

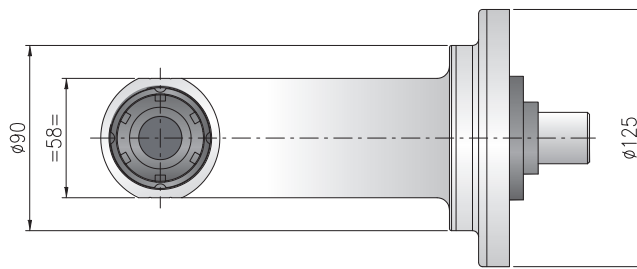

Minimum diameter without tool  
 Diametro minimo senza utensile  
 Durchmesser min. ohne

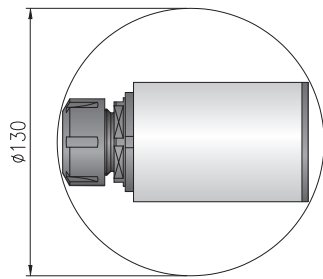

- Ratio**  
Rapporto / Verhältnis  
**1:1**
- RPM**  
Velocità / Drehzahl max.  
**6.000 min<sup>-1</sup>**
- Max. axial load**  
Max. carico assiale / Max. Axialbelastung  
**510 N**
- Torque**  
Momento torcente / Drehmoment  
**30 Nm**
- Weight**  
Peso / Gewicht  
**6,7 kg**
- Collet**  
Pinza / Spannzange  
**ER-25 Ø 1/16 mm**

**\* STANDARD EQUIPMENT INCLUDES:**

- Special bag - wrenches - Grease tube - Instruction book
- Bauletto - Ghiera ER chiavi di servizio - Tubetto di grasso - Libro istruzioni
- Spezialtasche - Schraubenschlüssel - Tube mit Fett - Bedienungsanleitung

Direction of rotation same as machine spindle / senso di rotazione uguale al mandrino / Drehrichtung gleich wie Antriebsspindel

Shank/Cono/Aufnahme						
	DIN-69871	CAT	MAS-BT	HSK	CAPTO	KM

**Option / Opzione / Option**

bar max <b>12</b>	min <sup>-1</sup> <b>8.000</b>	Ø mm <b>16</b>	Ø mm max. <b>16</b>	<b>HSK-32</b>	<b>ER-25/ER-16</b>
Coolant through spindle Adduzione refrigerante interna Kühlmittelzufuhr durch Spindel	High speed RPM max. Alta velocità RPM max. Drehzahl max.	Arbor output Porta fresa Fräseraufnahme	Welding output Weldon Weldon-Aufnahme	Quick Change Attacco rapido Schnellwechselaufnahme	Double output Doppia uscita Doppelter Ausgang

